

Installation Sheet – Feet Kit

Instructions:

1. After unpacking the CoolCube 10, use the base foam pad to raise the unit off the ground. **DO NOT TIP COOLCUBE 10 ON IT'S SIDE!** See Figure 1
2. Using the (8) screws and washers, attach the (4) compression mount feet to the corners of the base panel. See Figure 2
3. If you have any questions, please contact your CoolCube reseller or contact MaxPower at 800-576-3966 or sales@coolcube10.com

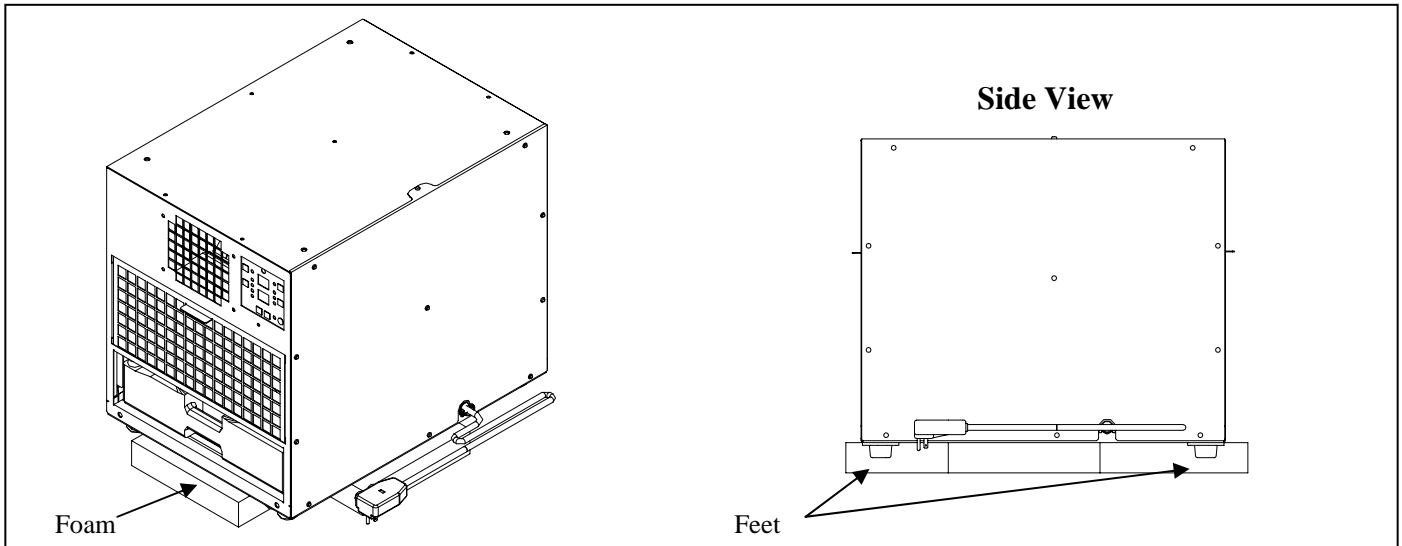

Figure 1

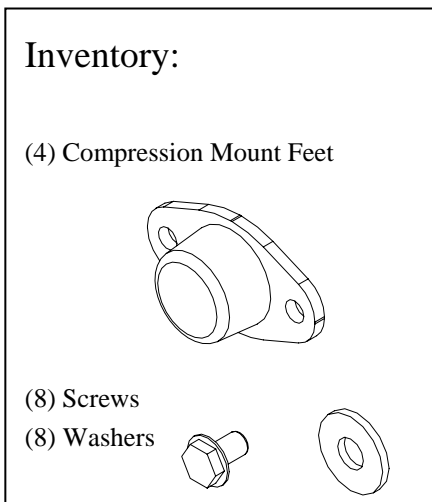
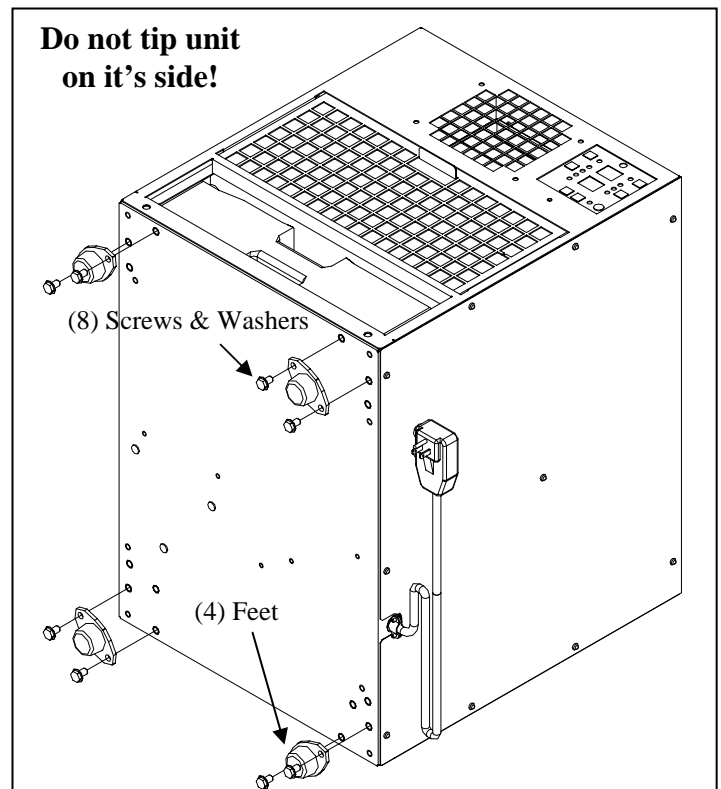

Figure 2



WARNING:

Do not tip CoolCube 10 units on their side! Figure 2 is for hole location illustration only. If the CoolCube 10 has been on it's side, the unit must be upright for at least 2 hours before starting the air conditioner. Failure to stand upright for 2 hours will result in damage to the CoolCube 10.