

Instructions:

1. Attach the 90 ° flange to the CoolCube 10 for warm and cold air ducting
2. For warm air ducting runs, attach the flange to the back side of the CoolCube 10 with the (4) screws and washers. See figure 1
3. For long cold air ducting runs, attach the flange to the front of the CoolCube 10 with the (4) screws and washers. See figure 2

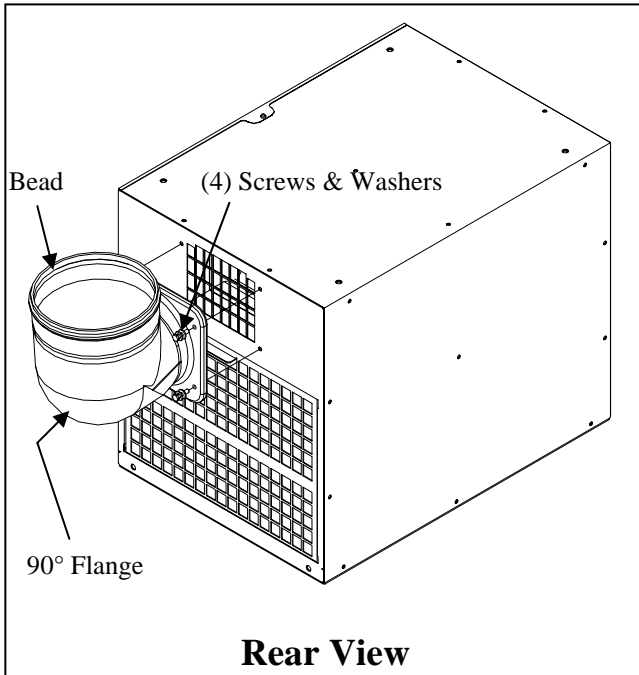

4. Place the eight-inch duct over the flange
5. Immediately after the flange's bead, secure the duct using the enclosed clamp
6. To maximize the ducting length, eliminate sharp bends and kinks in the duct wherever possible
7. If you have any questions, please contact your CoolCube reseller or contact MaxPower at 800-576-3966 or sales@coolcube10.com

Figure 1

Inventory:

- (1) 90 ° Flange
- (1) Clamp

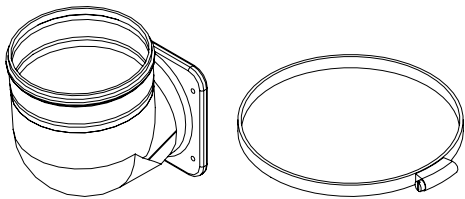

- (4) Screws
- (4) Washers
- (4) Lock Washers

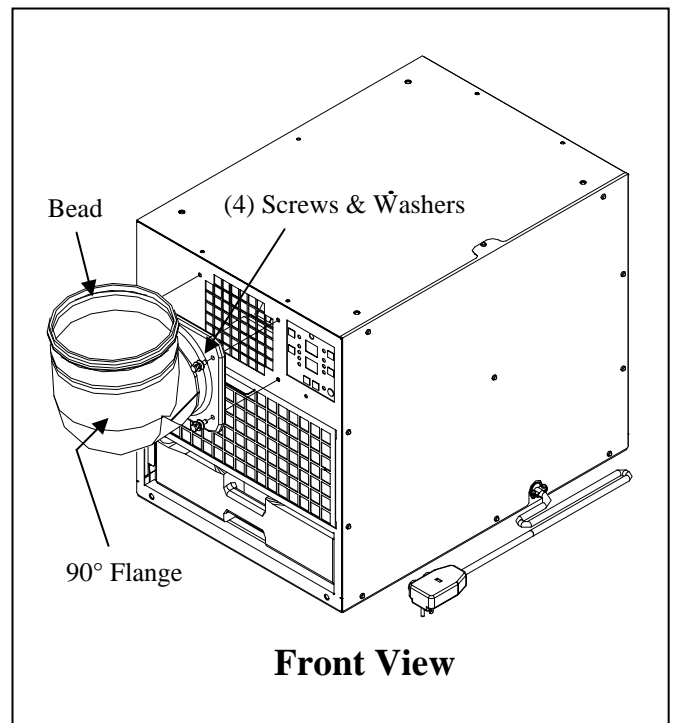

Figure 2